



# MOTION CONTROL

---

Heel Control • Trim Control • Roll Damping • Load Moment Control • Dock Control  
Tailored Control Systems • Monitoring • Engineering Service



# MOTION CONTROL

In order to fulfill operational, economical or safety requirements, crews are constantly facing the task to monitor and, if required, control the motion response of their ship or offshore structure. To cope with these challenging tasks more and more monitoring, control and automation equipment has been introduced to the infrastructure of maritime vehicles. Reflecting the developments of the past and considering the challenges of the future, the significance of the monitoring and the respective control tasks will become much more complex at a much larger scale.

Hoppe Marine has always been dedicated to develop and supply state-of-the-art, innovate and cost-efficient technologies to support owners and operators to conquer the challenges arising while undertaking their endeavors on the oceans. Our motion control portfolio ranges from standard cost-effective to highly sophisticated tailored systems. Our customers engage us to find the solution allowing them to accomplishment complex and difficult operations at sea. We focus on expanding the workability of their fleet. They trust our core ability to provide reliable measurements and efficient control technology for the maritime industry since more than six decades.

Over the years, Hoppe Marine has gathered a vast experience related to ship operations, design and integration of automation systems. The foundation is an experienced team of naval architects, data scientists, physicists, electrical and computational engineers. The complexity of our projects and their innovative character required us to develop and expand these capabilities. By acquiring FLUME® Stabilization Systems (2010) and INTERING (2017) we strengthened our position as the world market leader in the design and supply of passive Roll Damping and Motion Control systems.

## Content

---

About Hoppe	02	Load Moment Control	14
Heel Control	04	Dock Control	15
• Anti-Heeling	06	Tailored Control Systems	16
• Blower Anti-Heeling	07	Monitoring	18
Trim Control	08	Engineering Service	20
Roll Damping	10	Hoppe Systems and Components	22
• Flume® Roll Damping	12		
• U-Tank Roll Damping	13		



# ABOUT HOPPE

Hoppe is a family owned group of companies with global presence and activities focused and dedicated to the maritime market. It's passion for Technology has been the company's key of success in more than six decades with the permanent motivation to deliver customer-oriented products and services.

Starting with the business idea to deliver precise instruments and measuring equipment for seagoing vessels (ship speed and power), Hoppe Bordmesstechnik was founded in 1949 by the German engineer Dipl.-Ing. Hans Hugo Karl Hoppe. The work life of Hans Hoppe was characterized by many technical inventions and patents for on-board measuring systems. After 35 years of successful work life Hans Hoppe passed away and his colleague Jürgen Haas took over the company and put things on the right track for the future of Hoppe. Four years later (1990) Helmut Rohde joined Hoppe as partner before finally taking over all shares of the company in 1997. The Hoppe era of the Rohde family business started.

Besides many years of organic growth the Rohde family established business in further maritime markets to follow the globalization of the shipbuilding business. In 1997 Hoppe Korea was established, followed by Hoppe China in 2010 and Hoppe Singapore in 2017. In parallel, strategic investments were made with the acquisitions of Meramont Automatyka (Poland), MAIHAK Marine (Germany), Flume Stabilization (USA) and INTERING ship stabilization systems (Germany). Combined with many new inventions and patents Hoppe has established a leading position in several maritime business areas.

The passion for technology is still unbroken and all Hoppe products are fully designed in Germany by our skilled engineers. This means that Hoppe has the full technical control over its portfolio and remains dedicated to quality, accuracy and reliability. With this approach Hoppe has maintained a very good market reputation ever since.

Being a fully independent family-owned company Hoppe is well known in the market as a reliable long-term partner. Hoppe combines decades of engineering know-how, sustainable on-board experiences with the continuous development of new technologies and innovations. Based on the strategic product- and service-focus approach Hoppe is a key player also in the digitalization process of the marine industry.





# HEEL CONTROL

Hoppe is one of the leading suppliers of Heel Control systems in the maritime industry. The portfolio ranges from cost-effective standard solutions to tailored and highly sophisticated systems for complex and specialized applications. Heel Control systems are designed to keep any kind of vessel or offshore structure upright with respect to the permissible heel angle limit. The righting moment arising, causing the heel angle, is compensated by shifting ballast water between a set of heeling tank pairs located vis-a-vis on starboard and portside within the ship. The water transfer is achieved by utilizing centrifugal, reversible propeller, or screw-pumps and even air-blower units. The standard control system offers MANUAL, AUTOMATIC or

BALLAST mode operation via HMI – touch screen of PLC unit HOMIP or central PC-Station as well as connections to the alarm and monitoring system (IAS/AMS). In AUTOMATIC mode the system starts to compensate the heel angle when the threshold value exceeds  $\pm 0.5$  degrees heel. Sophisticated systems, required for loading operations at sea or offshore lifts, are controlled by measuring the actual heel moment generated and adjusting the individual flow rates. Then the control software offers additional operational modes such as ZERO FLOW, FLOW CONTROL and LOAD MOMENT CONTROL. Unique in the market is Hoppe's ability to combine heel compensation with roll damping functionalities in the same ballast water tank.



## KEY FEATURES

- Allocated knowledge of Hoppe, Interling and Flume in the design of Heel Control systems
- Experienced Naval Architects design the optimized and cost effective solution for standard and highly specialized applications
- Well proven and reliable key components
- Long reference list in large scale systems with a compensation rate of 10,000 tm/min are supplied and operate at the highest degree of reliability (up to 15 pumps sets or 4 blower units)
- Ice-heeling functionality for ice-breaking and ice-going vessels

## COMPONENTS

- Reversible propeller, centrifugal, screw pumps or air-blower
- Direct start, soft start or frequency controlled electric motors
- Electric pressure sensors for remote sounding of tank content or level switches
- Inertial Measurement System or inclinometer for determination of ship's heel angle
- Valve Remote Control System to control fluid flow with pneumatic, hydraulic or electro-hydraulic actuators
- Valve group for air flow control between 12" to 23".

# ANTI-HEELING

The heel compensation moment is achieved by transferring ballast water or other fluids between the heeling tank pairs using reversible propeller, centrifugal or screw pumps. Hoppe's reversible axial propeller pumps are an in-house design especially suitable for bidirectional water shift as required for Heel Control

systems. Three different pump sizes are available for vertical and horizontal installation as well as ex-proof execution. The pump performance is selected for each individual application by varying the gear set and motor type. Flow rates of up to 2,500 m<sup>3</sup>/h per unit can be provided.

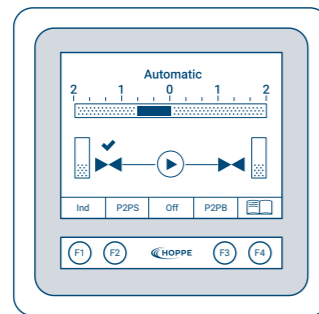

The PLC unit HOMIP for manual or automatic Heel Control function.

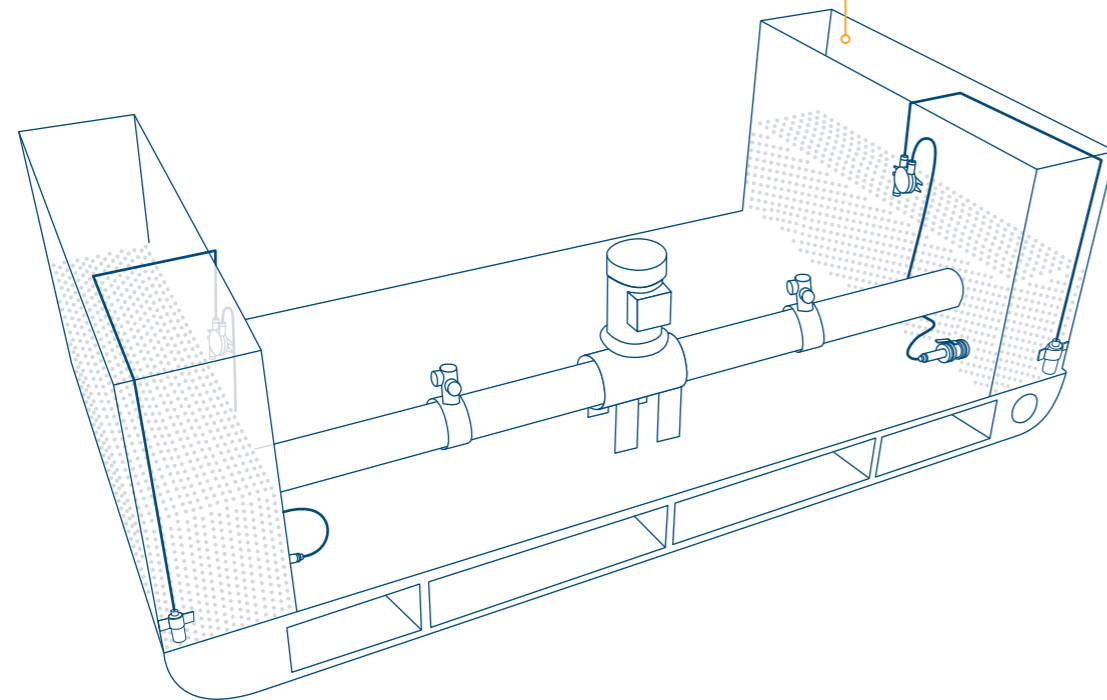

# BLOWER ANTI-HEELING

The closed system consists of one or more ballast water tank pairs which are connected with air-pipes on the top and water pipes close to the bottom. The compressed air from the blower unit(s) is used to shift the water between the tank pairs to generate the compensating moment. The direction of the air-flow is controlled by a valve group

to the tank and back to the atmosphere via a silencer. The system has extremely short response times in combination with high compensation rates. Blower Heel Control systems can be combined with U-Tank Roll Damping Systems and Ice-Heeling operational modes can be provided as additional option.

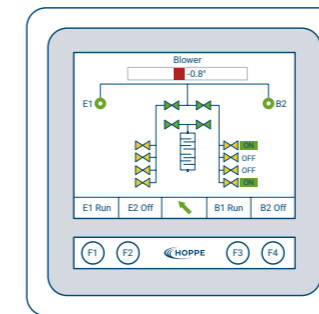

The PLC unit HOMIP for manual or automatic Heel Control function.

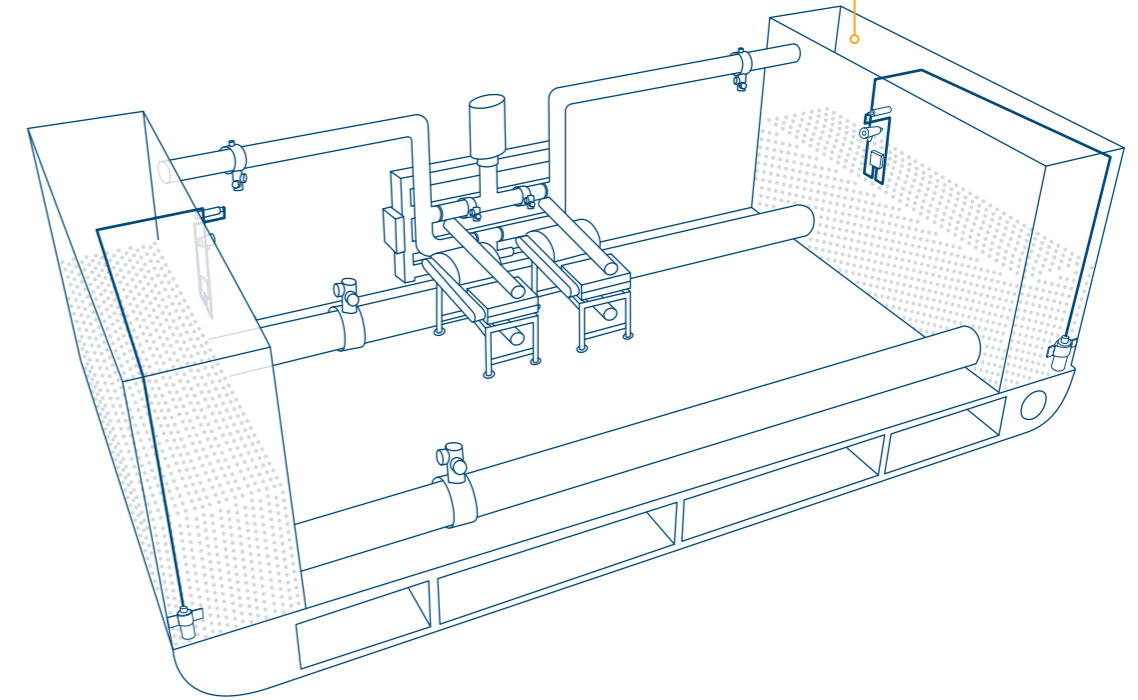



# TRIM CONTROL

Trim Control systems are designed to keep the trim of a RoRo ferry, a floating dock or any kind of ship within the predefined permissible limits during loading and unloading operations. The correction or adjustment of the arising trim is achieved by generating a counteracting moment through the shift of ballast water within the vessel or exchanging ballast water with the surrounding sea. Typically the system consists of two designated trim tanks, one located in the forward and one in the aft part of the vessel. The water shift or transfer can be realized with centrifugal or reversible propeller pumps and even air-blower compressors. The trim condition is determined by two draft measurement units located

in the forward and aft part of the ship. The control system offers MANUAL, AUTOMATIC or BALLAST mode operation via HMI – touch screen of PLC unit HOMIP or central PC-Station including connections to IAS/AMS. In AUTOMATIC mode the system starts to compensate the trim angle when the threshold value exceeds  $\pm 0.1$  meter. The Trim Control system can be combined with Heel or/and Draft Control systems. Then the control software contains adjustable parameters for automatic switch over between the different compensation functions including the automatic selection of suitable tank pairs, pumps or blower units.



## KEY FEATURES

- Allocated knowledge of Hoppe, INTERING and FLUME® in the design of Heel Control systems
- Experienced Naval Architects design the most flexible and cost effective solution for standard and highly specialized applications, ranging from one pump to multiple aggregates
- Well proven and reliable key components
- Combination with Heel and Draught Control systems
- Combination with Load Moment Control

## COMPONENTS

- PLC Monitoring and Control unit HOMIP
- Pressure Sensors for remote sounding of tank content
- Draft Units to determine the trim
- Valve Remote Control system for fluid flow control
- Centrifugal or reversible propeller pumps, or air-blower units to shift or exchange the ballast water

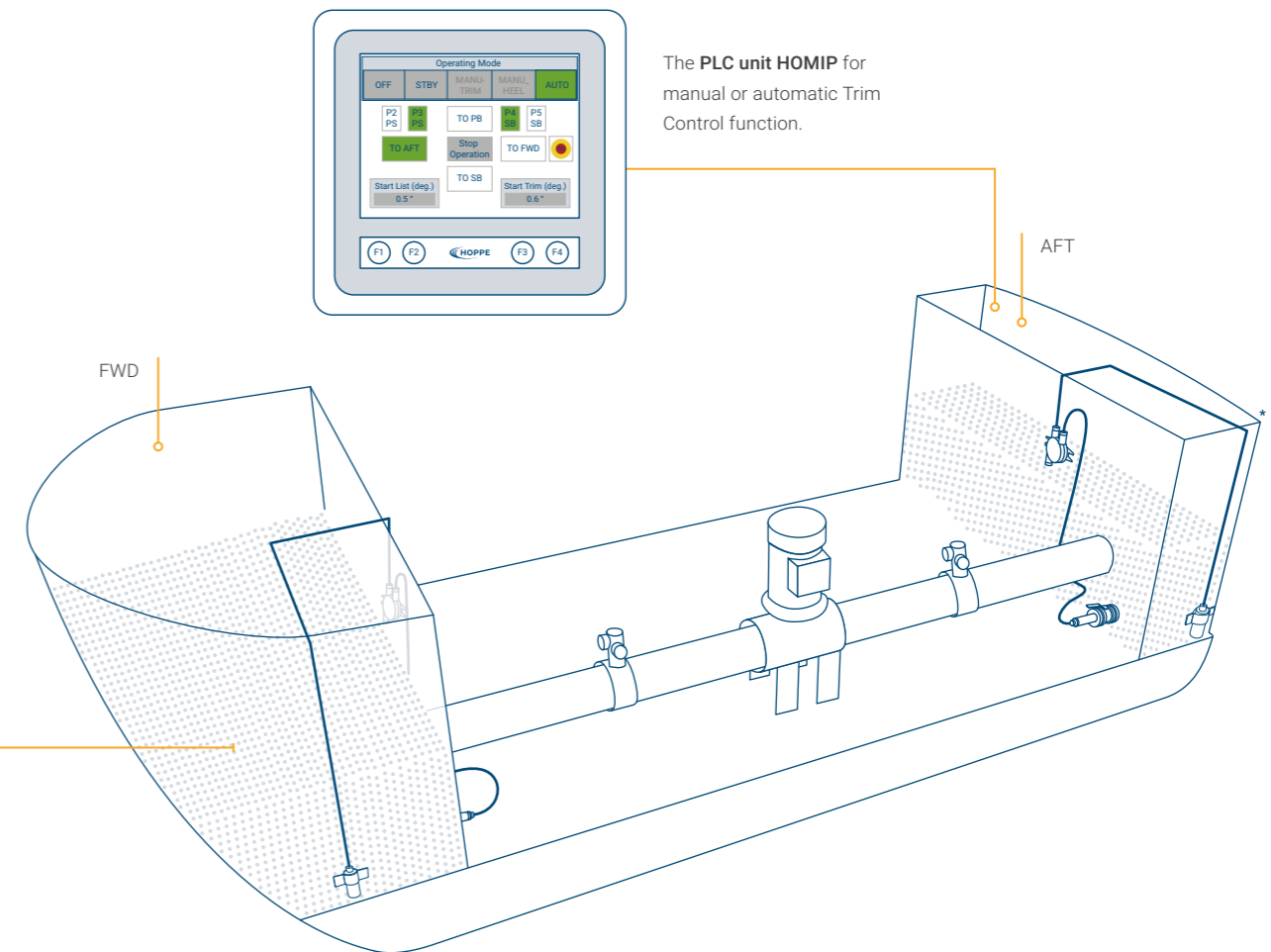

The PLC unit HOMIP for manual or automatic Trim Control function.

# ROLL DAMPING

As the world market leader in the design and supply of passive roll damping tanks Hoppe provides a large variety of tailor made solutions for all kinds of merchant ships and offshore vessels. Roll damping tanks use a hydrodynamically controlled flow of liquid within a specially designed tank, generally filled with ballast water, to create a stabilizing moment opposing the wave moment that is causing the ship to roll. The amount of stabilizing moment created depends on several factors, such as size and location of the roll damping tank, as well as hull form and loading condition of the particular ship. At Hoppe experienced Naval Architects individually design each roll damping tank for each specific

application. In order to verify the performance scaled model tests of the particular tank under realistic sea conditions are undertaken. Our more than 3,000 installations have been proven to be the most effective in the market for more than 60 years. With the acquisition of FLUME® Stabilization System (present in the market since 1957) and INTERING (present since 1969) Hoppe allocates the experiences of decades of know-how in the form of design, data and employees of the former two major players in the passive stabilizer market. In addition, the company is constantly developing the technology further using state-of-the-art simulation and testing equipment.



## KEY FEATURES

- Allocated knowledge of Hoppe, INTERING and FLUME® in the design of Roll Damping systems
- Experienced naval architects design practical solutions suitable for the particular vessel
- Validation of stabilizer design through scaled tank model test at state-of-the-art inhouse test facility (Hexapod)
- Investigation of the vessel's roll behaviour without and with stabilizer by using proprietary in-house sea keeping analysis programs
- Precise Monitoring and Control systems ensuring optimum Roll Damping performance and operational safety

## COMPONENTS

- HMI – PC-Station
- PLC Monitoring and Control unit HOMIP
- Electric pressure sensors for remote sounding of tank content
- Inertial Measurement System for determination of ship's roll motion
- Valve Remote Control System to control air or fluid flow





# FLUME® ROLL DAMPING

FLUME® is a passive free surface open channel box type roll damping tank. It has the unique ability to adapt to changes in the vessel's loading and operating condition. The stabilizers' natural response period can be adjusted by a liquid level variation to match the corresponding roll period of the ship. Equipped with a Liquid Level and Roll Period Indication System that constantly monitors the operating condition of the vessel and the stabilizer the

system assists the crew in achieving the maximum roll stabilization. As an add-on, the system can be upgraded with a designated pump to adjust the liquid level in the tank automatically, therefore no interaction of the shipboard personal is required. The FLUME® Roll Damping tank is especially suitable for vessels with a very large variance in loading conditions. As it has no moving parts maintenance and initial installation cost are relatively low.

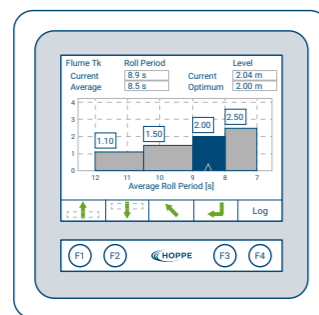

The PLC unit HOMIP for monitoring FLUME® tank liquid level and roll period.

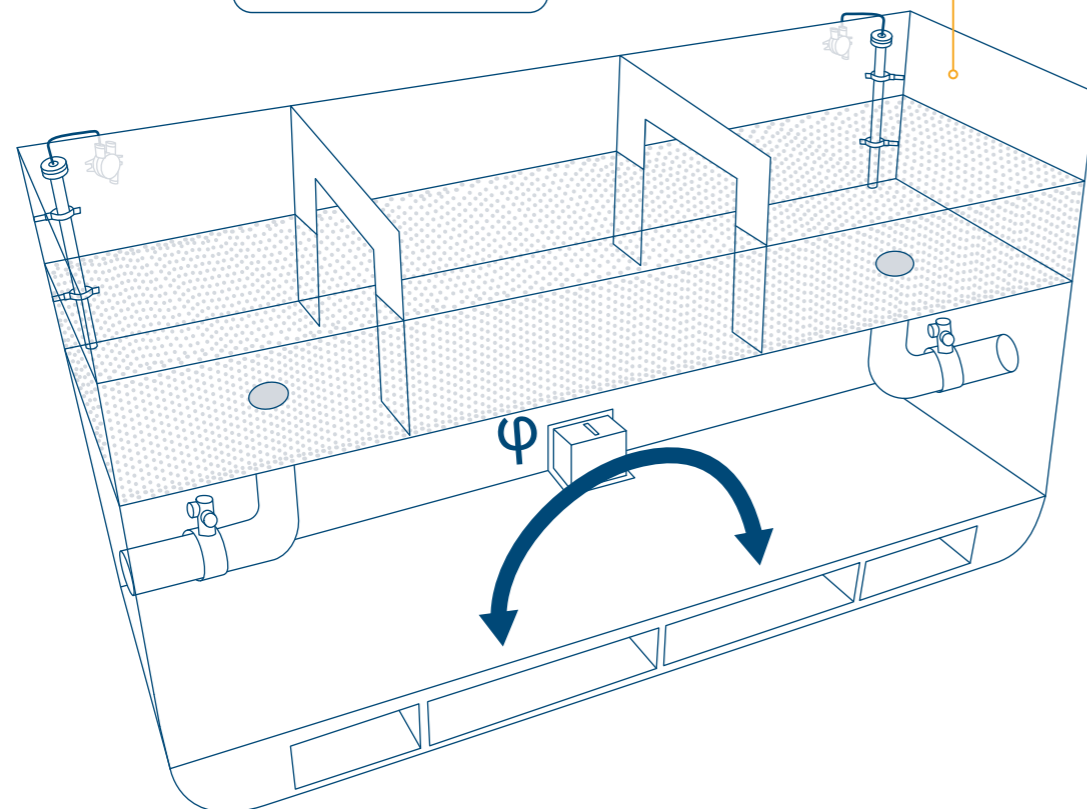

# U-TANK ROLL DAMPING

The U-Tank Roll Damping system uses a passive free surface U-tube type roll damping tank. The stabilizer consists of two wing tanks interconnected via a crossover duct either through or above the double bottom and a closed air duct system including remote operated valves. Hoppe offers different types of U-Tank Roll Damping systems. The difference is the control algorithm to adjust the natural response period of the stabilizer. The response period can be either adjusted by a variation in air damping, the

cross-sectional area of the water duct (Hoppe concepts) or by delaying the fluid flow (INTERING concept). Equipped with a monitoring and control system which automatically adjusts the response period of the stabilizer it can be operated safely and at maximum efficiency in all operating conditions. The air-damped U-tank is the most cost effective solution applicable for vessels with a relatively narrow band of variation in loading condition. For the INTERING system Hoppe provides only maintenance, services and upgrades.

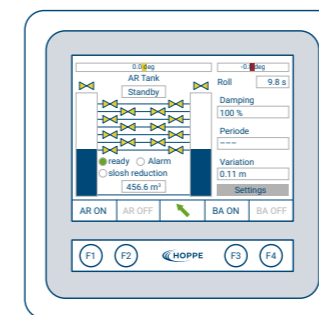

The PLC unit HOMIP for monitoring and control of U-Tank.

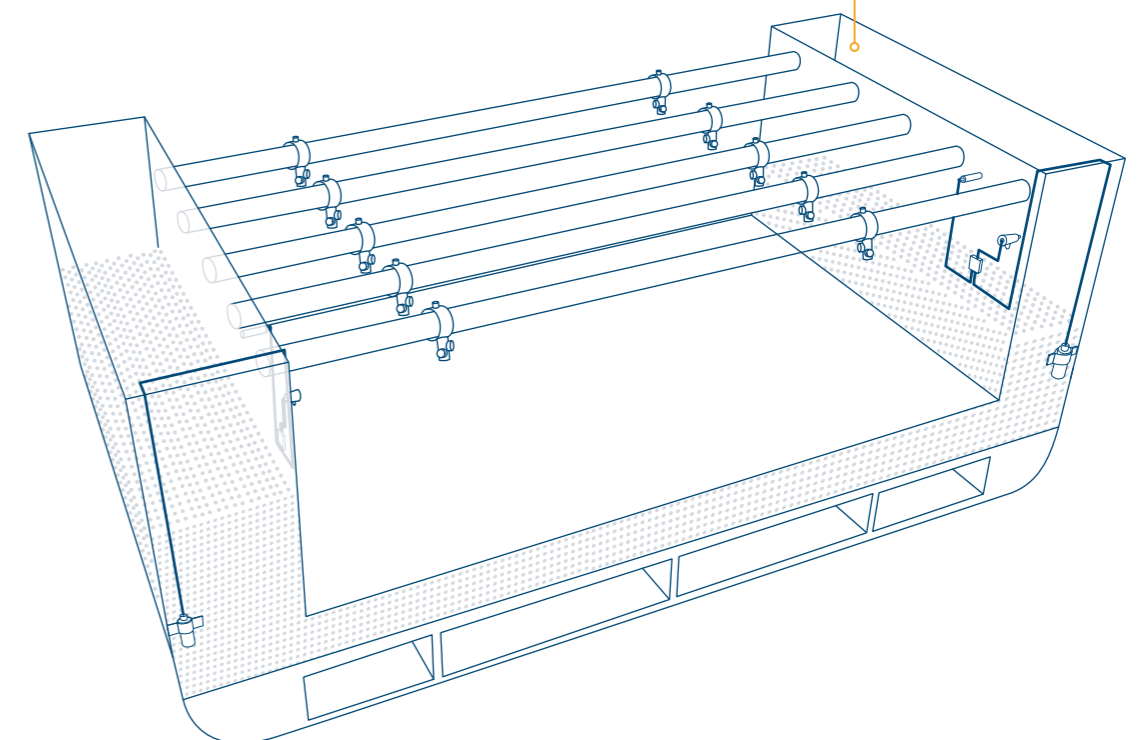



# LOAD MOMENT CONTROL

The Load Moment Control (LMC) algorithm considers the impact of the crane slewing process under a given load on the vessel's floating condition. LMC computes the exact magnitude of counter-acting moment to keep the crane vessel in the defined floating condition within a narrow window of tolerance. In principle, the "ballast follows the crane" by automatically shifting the required amount of ballast water in-between heeling tanks to compensate the crane's righting moment. This is achieved by controlling the individual flow, in a four-quadrant operation, in each heeling tank pair with frequency controlled reversible propeller pumps. The LMC mode includes general pump, turbine and

zero flow operation of the pump. The novel control algorithm was developed for Heerema's Aegir, a 210 m deepwater construction vessel for heavy lift and pipe laying installations. The vessel is equipped with a 4,000 t offshore crane with a radius of up to 40 m, located stern offset to starboard. Locating the crane off centre line to starboard introduced a significantly high overturning moment on the vessel that required a sophisticated Heel Control system to ensure a safe and economically feasible operation. The application of LMC fulfilled these demands and ensured to keep the Aegir upright in all operational conditions with +/- 0.5 degrees heel.



# DOCK CONTROL

The Hoppe Dock Control system is a scalable solution from manual dock operation (sinkage and lift) to fully automatic dock operation. The system combines all Hoppe system to fulfill the high technical demands.

- Central Dock Control station
- Pumps and Pump control
- Deflection monitoring systems
- Draught Measurement system
- Tank Content Measurement system and sensors
- Echo sounder
- Loading computer
- Hull stress monitoring
- etc.

The heart of the system is the dock load moment control system (DLMC). The Dock Control algorithm is based on the determination of the loads and moments introduced during operations of a floating dock. The loading computer COLOS is used to determine the entire loading condition of the dock including ship-to-be-docked prior execution of the docking procedure. The ship-to-be-docked is defined and intact stability, longitudinal strength and current floating condition are calculated. During a simulation of the docking procedure COLOS estimates the required ballast operations and flows in each individual ballast tank in order to undertake the sub-/emergence operation at leveled floating condition without exceeding the operational limits, such as intact stability, trim, heel and deflection.





# TAILORED CONTROL SYSTEMS

We are constantly engaged by our clients to develop monitoring and control systems fitting their ambitious projects to realize challenging and complex tasks in the maritime industry. Therefore, Hoppe Marine has been always expanding its capabilities to meet their customer requirements. Our ability to respond to these challenges by providing cost-efficient and tailored systems makes us a reliable partner in the market. We have reintroduced FLUME® type roll damping tanks on container ships. The damped motion response of the vessel results in decreased lashing forces and is used to boost container intake. The development of the Load Moment Control algorithm has enabled our customer to undertake heavy lifts automatically. All our offshore clients, such as Heerema, DEME, EMAS and others, are benefiting from this

technology leap, which provides high heel compensation rates in an instant at a high accuracy level. Projects with a single crane, located on starboard, off center-line, with crane lifting capacities up to 4,000 t have been realized to undertake heavy lifts fast and safely, even at sea. Recently, the algorithm has been further enhanced to enable automatic dock operations of floating, construction and combi docks or heavy transport vessels. The load moment is either measured or predefined in the loading computer. Simulations of the entire sub-/emergence procedure are undertaken under consideration of the operational limitations, such as trim, heel, draft, deflection and intact stability. A Dock Operation Computer is automatically executing the simulation considering the hydrodynamic behavior of the ballast system and the respective ballast pumps.



1 Controlling Load Moments 2 Combined Blower Heel Control and Roll Damping system 3 Loading Computer with Crane Operation Simulation  
4 Heel Control system with Zero-Flow 5 Draft Measurement, Tank Content Measurement and Valve Remote Control system

## REDUCING LASHING FORCES

Hoppe Marine has reintroduced FLUME® type passive roll damping tanks to container ships. At present, more than 50 container vessels ranging from small (2 k TEU) to ultra large (20 k TEU) have been equipped with the system. Customers benefiting from the technology are well established liner giants such as MAERSK and innovative niche market operators. The technology has been installed to utilize the positive effect of the reduced roll angles and associated accelerations on the magnitude of the lashing forces. The application allows to increase cargo intake and to store heavier containers more flexibly. Even for retrofits, the nominal number of container tiers and the maximum storable weight of each individual container has been increased.

## INCREASING ICE-BREAKING CAPABILITIES

For icebreakers and vessels with ice-breaking capabilities Hoppe provides a specialized ice heeling system. The blower-driven Heel Control system is utilized to actively generate a continuous heeling motion from port to starboard and back. Only the fast reacting and high capacity blower unit is able to generate the required large heeling moment in the required short time span.

## SIMULATING LOADING OPERATIONS

Hoppe Marine provides onboard software solutions to simulate offshore operations, heavy lifts or automatic loading transfer operations, like the docking of a vessel in a floating dock or on a heavy transport vessel. The simulators are based on the loading computer infrastructure COLOS. The aim is to support the shipboard personnel with a reliable and realistic tool to undertake the planning of the respective operation. Besides all standard modules, such as intact and damage stability and longitudinal strength, special modules for cargo handling are provided. In addition, hydrodynamic characteristics of pumps, hydraulics of the ballast piping, valves and tanks are implemented in order to ensure realistic simulation results. In combination with Hoppe Marine's Valve Remote Control, Tank Content Measurement, pump control and vast number of the monitoring system, we even offer

an automatic execution of the simulated operation. In these cases the simulator supervises the execution and optimizes the target values so that operational limits such as trim, heel, deflection and stability requirements are fulfilled. The loading computer software including the simulator is also available as an office version.

## CONTROLLING LOAD MOMENTS

Hoppe Marine supplies complex and sophisticated Heel Control systems which keep ships upright during construction, heavy lift and offshore installation operations. For clients, such as Heerema, DEME and Subsea 7, the Load Moment Control (LMC) algorithm has been developed.

The novel working principle is: "ballast follows the crane" by generating the exact amount of heel moment required to counteract the crane's righting moment. The flow of each individual heeling pump can be continuously adjusted between "zero-flow" and the maximum flow capacity. LMC ensures a smooth, uninterrupted and safer crane operation at significantly reduced operation time. Hoppe's advanced Heel Control systems are capable to keep the maximum heel angle below  $\pm 0.5$  degrees.

## ENABLING AUTOMATIC DOCK OPERATIONS

Floating docks and semi-submersible heavy transport, decommissioning and multi-purpose dock vessels undertake sub-/emergence operations to lift marine structures and ships. Hoppe's Dock Control systems offer automatic ballast operations. Ballast operations are automatically undertaken under the control of the loading computer. Draft, trim, heel, deflections and stability requirements are controlled to not exceed the operational limits.

## COMPUTER AIDED INCLINING TEST

The Stability Test system provides the exact actual GM of the vessel by carrying out a Computer Aided Inclining Test (CAIT). The required heeling moment is achieved by the Hoppe Heel Control system. During the test draught, the heeling tank contents and heel angle are measured by Hoppe's tank and draught measuring sensors.



# MONITORING

As a system provider with a high degree of vertical integration and component competence Hoppe provides onboard proven hardware and sensors for the monitoring of major parameters required for the control of the motion response of any kind of floating object. All solutions are in-house designed or sourced from reliable partners tailored

to the marine industry demands. Constant enhancement of the equipment and high quality standards ensure the fulfillment of the highest market standards to meet the market demands for smart and integrated sensors. All our monitoring equipment is dedicated to accuracy, reliability and ease of operation for onboard use.



## TANK CONTENT MEASUREMENT

The system continuously monitors the contents and temperatures of ballast, cargo, fuel oil, and other liquids tanks. The electric pressure type sensors are a special in-house design for marine applications, reliable, accurate and at highest levels protected against medium ingress and corrosion.

## ELECTRONIC INCLINOMETER

The Electronic Inclinometer consists of an embedded sensor (sensor and computer in one common box) with interface ports and a bridge display unit according to IMO Annex 23 stipulations. The sensor allows real-time high sampled motion data to sufficiently measure the heeling at sea.

## SHIP'S INERTIAL MEASUREMENT

HOSIM is a highly-accurate inertial measurement unit for the determination of roll and pitch angle, associated periods, as well as trim and list. The information provided by HOSIM can be used by subsequent systems or by nautical staff to better evaluate questions regarding cargo safety, ship performance and general ship safety.

## DEFLECTION

Based on the "hose water level" principle the system measures deflection and torsion. It is a hydraulic system – filled with water – with electric pressure sensors distributed in longitudinal and transverse direction of the particular object. For example, for floating docks the system is installed below the pontoon deck.

## RELATIVE POSITION

With radar sensors the relative position between emerged objects can be measured. The sensors are distributed in longitudinal and transverse direction of the floating device. The system is used for launching platforms, heavy transport vessels or floating docks to assist the determination of the exact position of the dock piece before undertaking the ballast operation.

## LASHING FORCES

The Cargo Safety module is an add-on based on Hoppe's Inertial Measurement unit (HOSIM), allowing to monitor lashing forces at any predefined point on a solid body. The system allows the crew to freely set points of interest where critical levels of acceleration and respective lashing forces arise onboard of any kind of vessel.

## HYDROSTATIC DRAUGHT

The system measures and monitors the vessel's draught condition continuously. It determines the draught values precisely at perpendiculars and draught marks. The standard configuration includes four electric pressure sensors.

## DYNAMIC TRIM AND CONNING

TRIMCON is a satellite-based system for the real time monitoring of a ship's dynamic trim, heading and speed in longitudinal and athwart direction. The system assists the Nautical Officers with precise information on actual pitch angle and dynamic trim, and monitors the ships' fore and aft relative motion with high accuracy during maneuvering (Conning).

## LOADS & MOMENTS

Load cells are used to determine the moments causing the vessel to change its floating condition (trim, heel and draft). With the help of these measurements the exact amount of counteracting ballast moment can be determined to automatically compensate variations in trim, heel and draft during loading operations.

## LOADING CONDITIONS

The loading computer software package COLOS is used to calculate the loading condition of any kind of vessel or offshore structure based on a theoretical model. COLOS allows the determination of the floating condition, intact and damage stability, longitudinal strength and special modules, such as cargo handling and simulation of dock operations. The software can access interfaces to consider external data for calculation and monitoring.



# ENGINEERING SERVICE

Over the years, Hoppe Marine has gathered extensive knowledge in regards to ship design, ship theory, estimation of seakeeping behavior and simulation of fluid dynamics. The complexity of our projects and their innovative character required us to develop and expand these capabilities. Nowadays, our clients demand our expert knowledge and trust us to provide third party opinions. Given the tremendous background in ship operation, the related innovative automation products and the practical system integration know-how, it was a logical step for us to offer this expertise as an engineering service to our customers. The engineering portfolio is focused on Hoppe Marine's core capabilities Motion Control, Fluid Management and Ship Performance. The foundation is an experienced team of naval architects, marine engineers, data scientists, physicists

and computational engineers. We offer scaled model tests on a state-of-the-art 6 degrees-of-freedom (DOF) motion platform, numerical motion response analysis, computational fluid dynamics (CFD) calculations and optimizations, engineering consulting, data analysis, sea trial attendance and surveys undertaken by our experts. The Marine Hydrodynamics team supports all departments within Hoppe in dealing with all naval architectural challenges encountered. In addition, we assist and/or advise our clients, yards, design offices and end-users on integrating our equipment during the development of a vessel or during conversions and retrofits of existing designs. Outside the supporting role, we constantly develop our numerical, analytical and test procedures to support the creation of innovative products ready for the future.



## SCALED MODEL TESTS

Hoppe operates a very sophisticated facility to conduct any kind of sloshing or other moving objects model tests. The test field is equipped with a state-of-the-art Mistral Hexapod (2017), a high precision six DOF force and moment sensor, different motion sensors, resistance probes and a high resolution camera system to track fluid or solid object movement. In day-to-day business the setup is mainly used to validate the performance of FLUME® type, INTERING type or U-Tube stabilizers. In addition, Hoppe is offering its model test expertise to clients to investigate any arising problems in respect to marine engineering or naval architecture, such as sloshing issues of swimming pools, moon pools and LNG-tanks. Furthermore, critical stowage issues of e. g. explosive materials and sensitive equipment can be evaluated.

## MOTION ANALYSIS

On a daily basis Hoppe's experienced Naval Architects are working with a variety of seakeeping tools to evaluate the motion characteristics of any kind of vessel type in regards to any kind of maritime-related problem. The tool set ranges from cost-effective and quick 1-DOF roll response estimations to complex and detailed RANSE-based 6 DOF motion solvers in the time domain. If necessary, the entire spectrum of available numerical techniques can be applied to determine the motion behaviour of the marine object at sea. The results are post-processed to derive the probability of the motion response in the respective sea state. The basis is an extensive database of worldwide scatter diagrams in irregular seas.

## COMPUTATIONAL FLUID DYNAMICS

Hoppe has heavily expanded its capabilities to numerically evaluate and solve problems related to fluid dynamics. The logical steps perfectly complement the vast experience gained in system integration and automation. A team of computational engineers applies commercial and open source state-of-the-art empirical, potential or RANSE CFD solvers in day-to-day business to support the design and engineering of our products and systems. In addition, Hoppe offers its CFD expertise to its clients to undertake studies to resolve practical issues arising during the operation of vessels.

## CONSULTING & DATA ANALYSIS

During daily operations ship owners and their crews are faced with a variety of optimisation, motion response and cargo handling issues. In most cases these problems can be resolved based on their practical experience. However, very often expert know-how in the area of ship theory, seakeeping, intact and damage stability, pump and crane operation, as well as automation and system integration is required. Hoppe employs an experienced team of Naval Architects, former nautical officers, physicists, data scientists, computational engineers and electrical engineers to advise their clients in regards to any kind of operational and theoretical problem related to the maritime industry. The service is based on the profound knowledge of how to provide reliable data for the evaluation. Decreasing risk factors arising from excessive roll motion for cargo, humans and the ship itself are our specialty. However, our clients also rely on us to optimize the sailing condition of their vessel in order to decrease the overall fuel consumption. Our aim is to provide the customer with a solid basis for their decision making process and assist them for achieving the best technical solution to their problem. We are focused on increasing workability, flexibility, cargo intake and safety.

## SEA TRIAL ATTENDANCE

Hoppe Marine offers its skilled Naval Architects and experienced Trial Engineers to attend the vessel in order to evaluate the problem during actual operational conditions. Our trial team will be equipped with a reliable and precise set of portable data acquisition equipment to gather the required input for the analysis. An interface to a variety of external data sources can be accessed. We conduct dedicated testing procedures that allow profound comparisons of the outcomes on board with design and engineering data or with simulations and predictions made beforehand. One of our most cost-effective solutions is the portable Maihak shaft power meter used to acquire a reliable measurement of the power consumption during sea trials of propulsion systems. Via such an analysis potential fuel savings can be made visible. As a third party consultant Hoppe offers these services also for systems of other vendors.



# HOPPE SYSTEMS AND COMPONENTS

	Electronic Devices		Valve-Actuator-Combinations				Motion Sensors			Heel Control and Trim units		Level Sensors			Power and Performance Meter		
	PLC unit HOMIP	I/O Modules	HOPAC (pneumatic)	HOHAC (hydraulic)	HOHEA (electro hydraulic)	electric	Inclination Sensor	Electronic Inclinomometer	Inertial Measuring unit HOSIM 2	GPS Sensor	Reversible propeller pump	Blower unit	HCG2011 (electric)	HCG 4011 (electric BUS)	HOBUB (pneumatic)	Shaft Power Meter	Fuel Counter
<b>Fluid Management</b>	Valve Remote Control	•	•	•	•	•											
	Tank Content Measurement	•	•				•						•	•	•		
	Ballast Management	•	•	•	•	•	•						•	•	•		
	Bunker Management	•	•				•		•				•	•	•		
	Draught Measurement	•	•				•						•	•	•		
	Dynamic Draught Measurement	•	•				•		•	•			•	•	•		
<b>Motion Control</b>	Heel Control	•	•	•	•	•	•		•		•	•	•	•			
	Trim Control	•	•	•	•	•	•		•		•	•	•	•			
	FLUME® Roll Damping	•	•	•	•	•			•				•	•			
	U-Tank Roll Damping	•	•	•	•	•			•				•	•			
	Load Moment Control	•	•	•	•	•	•		•		•	•	•	•			
	Dock Control	•	•	•	•	•	•		•	•	•	•	•	•	•		
<b>Ship Performance</b>	Maihak Shaft Power Meter	•	•													•	
	Fuel Consumption Measurement	•	•													•	•
	Trim and Motion Measurement	•	•							•							
	Performance Monitoring	•	•						•				•	•	•	•	•

# COMPACT OVERVIEW

## Fluid Management

- Valve Remote Control
- Tank Content Measurement
- Bunker Management
- Ballast Water Management
- Draught Measurement
- Dynamic Draught Measurement
- Sensor Toolbox HOSET



## Motion Control

- Heel Control
- Trim Control
- Roll Damping
- Load Moment Control
- Dock Control
- Tailored Control Systems
- Monitoring
- Engineering Service

## Ship Performance

- Main Shaft Power Meter Power Meter
- Fuel Consumption Measurement
- Dynamic Draught, Trim and Motion Measurement
- Performance Monitoring
- Fleet Data Quality
- Analysis Catalog



## Ship Services

- Technical Support
- Spare Parts
- On Board Service
- Retrofit
- Service 4.0
- Predictive Maintenance and Self-Validation
- Fleet Data Quality
- Analysis Catalog
- Hoppe Global Service Points



## **CONTACT**

### **Germany**

Hoppe Marine GmbH  
Kieler Straße 318  
22525 Hamburg

Tel. +49 (0)40 561 949 - 0  
sales@hoppe-marine.com

### **China**

Hoppe China Co., Ltd.  
German Center, Room 708,  
Tower 1, 88 Keyuan Road  
201203 Shanghai Pudong

Tel. +86 21 50 278 040  
service@hoppe-china.com

### **Singapore**

Hoppe Singapore Pte., Ltd.  
18 Boon Lay Way # 04-93  
609966 Singapore

Tel. +65 67 17 48 88  
service.singapore@hoppe-marine.com

### **Republic of Korea**

Hoppe Korea Co., Ltd.  
No 485-3, Gu Pyeong-Dong,  
Sa Ha-Gu  
604-866 Busan

Tel. +82 51 4 035 851  
hoppe@korea.com